



Traction transformer service supporting reliable and sustainable transportation

There are several untenable situations that train operators face – situations that prove expensive to them in terms of

costs, reputation, and viability. These are the factors that could cause them “pain” in both the short- and long-term. Some may face train stoppages due to

unplanned traction transformer outages. There is a potential danger and risk for people and the environment due to possible oil leakage.

Hitachi Energy is continuously trying to innovate and perfect its products and services by offering more environmentally friendly, resource-use-efficient products that are undemanding of too much maintenance



Fortunately, Hitachi Energy's long experience and expertise in the field of traction transformers and their service deliver the perfect solution for all these issues, endeavoring to prevent instead of simply cure. We at Hitachi Energy are continuously trying to innovate and better our products and services by offering more environmentally friendly, resource-use-efficient products that are undemanding of too much maintenance.

TransForLife solutions™ is the complete package of on-board traction transformer services that Hitachi Energy offers its rail customers, both train manufacturers and owners / operators. The on-board traction transformer is a crucial component in the rolling stock traction chain. Rather than react to problems when it is too late, TransForLife Solutions™ make it possible to predict and rely on traction transformer performance with confidence.

The TransForLife Solutions™ portfolio is essentially a one-stop service support facility for all on-board traction trans-

former needs. These rail care solutions are organized as modular service concepts according to the needs and requirements of the clients:

- **Rapid response:** fast and flexible expert services are offered to maximize on-board traction transformer and rolling stock availability
- **Lifecycle management:** knowledge and expertise are provided to optimize and extend equipment lifecycle with strategic spare parts
- **Performance improvement:** enhancing rolling stock performance, reliability, and lifetime through powerful tools to reduce the risk of outage



Underframe traction transformer for EMU retrofit project in the UK

The Field Service / TrafoSiteRepair™ service offering provides on-site maintenance service to keep rolling stock running

Our dedicated service centers and traction transformer experts are constantly on standby to keep all the equipment running and online; they extend factory repair and remanufacturing services under the am-

bit of TransForLife Solutions™. Midlife overhauls, upgrades, and retrofits – these services enhance the longevity and performance of existing equipment with the latest technology. Our attempt is to enable

sufficient rolling equipment buffers with the customers so that they may tide over unexpected problems. The customer's staff is trained thoroughly and appropriately so that many problems and issues can be dealt with at the customer's end. The Field Service / TrafoSiteRepair™ service offering provides on-site maintenance service to keep rolling stock running.



We try to contain damage so that the repairs remain small jobs that can be carried

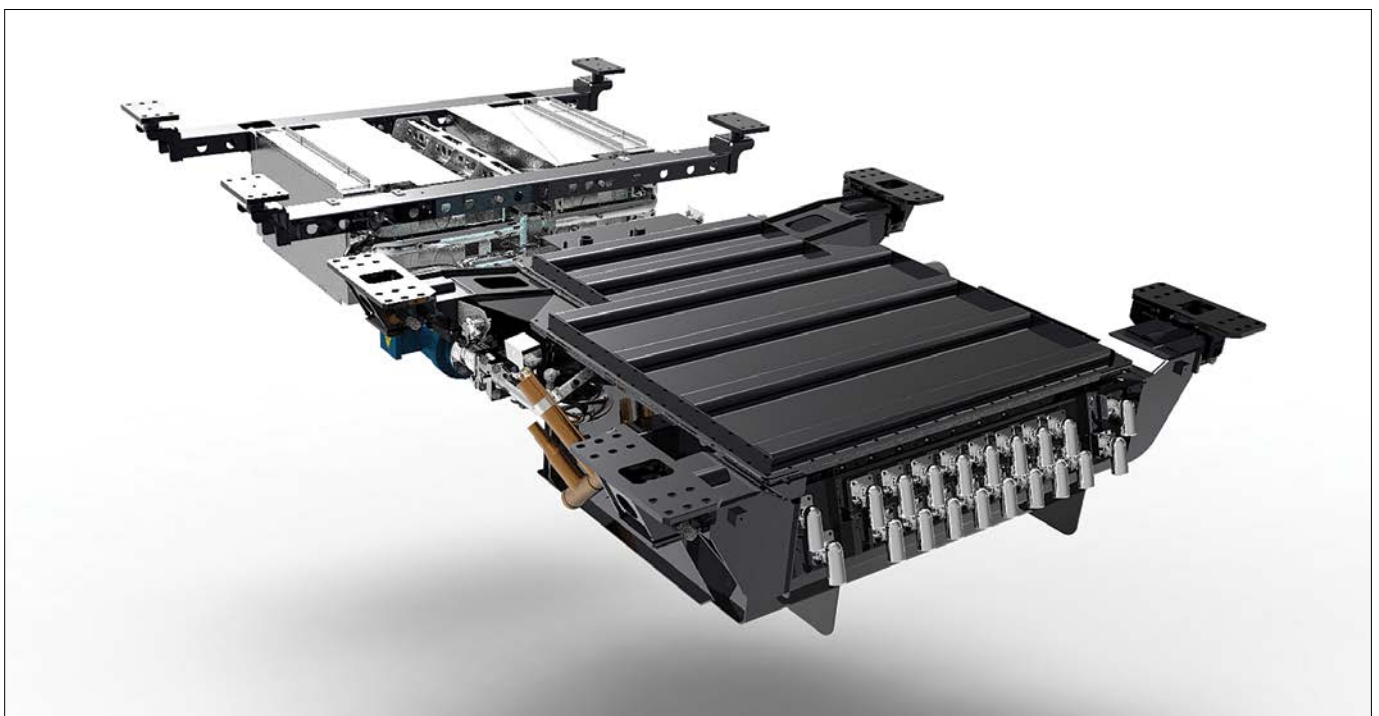

Underframe traction transformer for a very high speed train retrofit in Sweden



Underframe traction transformer for a very high speed train in Italy

 <p>Installation/Supervision A great investment in the long-term trouble-free operation of your equipment</p>	 <p>Training The best way to ensure your people have the specialized skills they need</p>	 <p>Spare Parts Genuine spare parts for all on-board traction transformers</p>
 <p>Factory Repair/ Remanufacturing Our service engineers are standing by to get your equipment back on-line as soon as possible</p>	 <p>Field Service/TrafoSiteRepair™ On-Site Maintenance Service to keep your rolling stock running</p>	 <p>Advanced Services Helping you to optimize costs and performance over the entire lifetime of your product</p>
 <p>Midlife Overhaul, upgrades & retrofits Enhance your existing equipment with the latest technology</p>	 <p>Replica / Spare Transformer Replacing older traction transformer by Replica can drastically increase performance & reduce costs</p>	 <p>Service Agreement The most efficient way to manage the total life cycle of your equipment</p>

One-stop service support for all on-board traction transformer needs

HITACHI Energy - TransForLife Solutions™ Service Portfolio for on-board traction transformers

out at the customer's premises instead of needing to cart the equipment off to the factory for repair.

Replica / Spare transformers can be supplied – this service essentially covers the risk of service interruption in case of major damage – even for old designs from the last century or more recent ones manufactured in the last decade. Genuine spare parts and / or Replica spare units for on-board traction transformers are always available. Finally, advanced services, digitalization, and service agreements are offered to conduct preventive maintenance and optimize costs and performance over the product's entire lifetime, and efficiently manage the total life cycle of the equipment.

From trains to cable cars to vessels, buses and even planes – Hitachi Energy delivers continuous solutions for the electrification of transportation. By providing a comprehensive portfolio of products, systems, services, and software solutions, we enable more sustainable, flexible, and secure passenger transportation – and this is what we showcase as our strengths at the Innotrans 2022 Rail fair in Berlin.

[Traction transformers | Hitachi Energy](#)

[Transformer service | Hitachi Energy](#)

From trains to cable cars to vessels, buses and even planes – Hitachi Energy delivers continuous solutions for the electrification of transportation



Author



Vincent Moine joined ABB in 2000 and held various positions in Sales and Project Management in various countries (Germany, France, Finland and Switzerland) with 20 years of experience in Transformer Service. He currently serves as Global Sales / Channel Manager – Hub Europe for Traction Transformer Service in Hitachi Energy Switzerland since 2020. He holds an Engineering degree in Industrial Engineering and Business Management from the University of Lyon, France.